

Power Quality Solution

Power Xpert™ 9395 UPS  
200 - 1100 kVA

Unmatched  
green power



**EATON**

*Powering Business Worldwide*

# Introduction and overview

As IT managers, facility managers and CIOs face increasing pressure to achieve zero downtime, reduce energy costs by scaling down data centres and meet sustainability requirements, the quest for the most reliable and efficient power protection system has become more critical. With an unprecedented level of power performance, reliability and energy savings, Eaton® has raised the bar in three-phase power protection technology with the Power Xpert™ 9395 UPS, the state-of-the-art product from the Powerware® series.

## Key applications

- Large data centres
- Server farms
- Telecommunication installations
- Internet service providers
- Transportation systems
- Security operations
- Broadcasting and entertainment
- Process control equipment
- Financial systems
- Credit card operations
- Industrial systems
- Healthcare
- Multiple medical imaging units

**The 9395 delivers a wide scope of superior customer-driven benefits:**

### Premium power performance and true reliability

- Enhanced power protection due to double-conversion design and lower ITHD
- Dependable operations with Powerware Hot Sync® paralleling technology
- Option to build parallel systems either with distributed or centralised static bypass switch
- Increased reliability through inherent redundancy and Intelligent Power® software
- Longer battery runtimes due to higher efficiency and ABM® technology
- Higher availability through concurrent maintenance

### Lower TCO through sustainable design

- Savings on source materials, space and freight costs due to reduced footprint and weight
- Reduction in energy consumption during manufacturing, testing and use
- Electrical and cooling cost savings due to higher up to 99 per cent efficiency with EAA technologies
- Flexible, upgradeable architecture for future expansion needs
- Longer component life due to higher efficiency
- Installation and testing savings with the Easy Capacity Test
- Reduced end-of-life impact because the materials are recyclable



# Premium power performance and true reliability

## Double-conversion design for highest power protection

Eaton's double-conversion design outperforms the competitors by completely isolating output from input power anomalies, while regulating both voltage and frequency to deliver 100 per cent conditioned, perfect sine wave output. Even under the most severe power disturbances, power output remains stable with the Power Xpert™ 9395 UPS.

## Enhanced power performance

Power performance is measured by system efficiency, ITHD, and input and output power factor. A robust combination of these elements makes the Power Xpert™ 9395 the premier UPS in its class.

The 9395 delivers an efficiency of up to 94.5 per cent. This high level of performance is powered by modern transformer-free technology with small, lightweight filter inductors, high performance IGBTs in the rectifier and inverter, and an advanced control algorithm. The graph on the right shows how efficiency generally dips as load level decreases. In general, manufacturers list an optimal efficiency rating at full load. In reality, however, most three-phase UPSs operate in the range of 30 – 50 per cent load. The 9395 can provide exceptional efficiency at half load capacity.

Additionally, because of IGBT technology, the 9395 does not require input filters to obtain excellent input ITHD, unlike most other manufacturers, whose UPSs require input filters that ultimately lower their efficiency rating. Due to low input ITHD (less than 3 – 5 per cent) and high input power factor (over 0.99), the 9395 is exceptionally compatible with diverse power sources, especially generators, but is also mains friendly due to its low harmonic content.

On the output side, the 9395 supports leading power factor loads, which are becoming more prevalent in new and updated data centres, thus delivers its full power capability. The 9395 handles, without derating, down to 0.8, which is the leading power factor of modern computer and server loads.

These technological innovations result in dramatic cost savings, given extended battery runtime, longer life of components and cooler operating conditions within the UPS.

Efficiency vs. Load

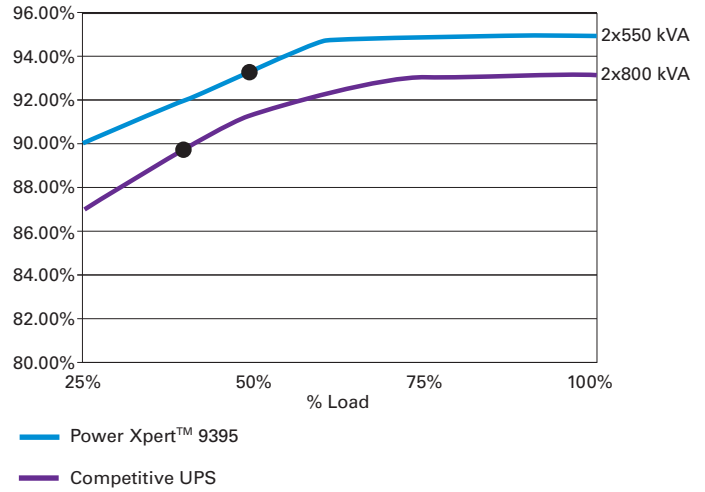

### Powerware Hot Sync technology boosts system reliability

In systems with multiple uninterruptible power modules (UPMs), the 9395 leverages the synchronization, load sharing and selective trip capabilities of Eaton's patented Powerware Hot Sync technology. These capabilities are integral to the ultimate systems availability that is the primary requirement for any parallel UPS configuration.

The Hot Sync system functions automatically without any dependence on centralized, external control.

Powerware Hot Sync utilizes a peer to peer control architecture, as opposed to the ubiquitous master/slave controls found in competitive systems. This unique architecture eliminates the need for a single UPM/UPS to depend on any outside source for its control. The multiple UPMs/UPSs simply monitor their own internal metering, and use simple mathematical computations to remain synchronized, share the load equally, and detect and isolate malfunctions. This architecture does not require extra circuitry or added complex wiring in order to function in parallel. Therefore, it eliminates huge bundles of control wiring, hundreds of electrical connections, removes the need for a failure-prone central control thus eliminating complexity and enhancing reliability.

Ultimate reliability in the implementation of parallel AC power systems guarantees system autonomy and simple instrumentation.

#### Sync Control

Sync Control ensures that the output of two (or more) separate UPSs (single modules or parallel systems) remain in phase with one another so static transfer switches connected between the separate distribution paths may change state seamlessly when necessary.

#### Inherent redundancy option for highest availability

Surveys focused on efficiency in data centers reveal that UPSs are often underloaded—frequently at less than 50%. To capitalize on this trend and create even greater reliability, you have the option to configure the multi-module 9395 with inherent redundancy. Anytime the load is below 50% capacity, it is automatically redundant. This option might be the single most important feature that saves customers from dropping their load. Traditional UPS manufacturers cannot deliver this additional availability without adding a more costly second UPS module.

#### Scalable, redundant architecture for current and future needs

The 9395 combines the reliability and redundancy of a multi-module UPS into an integrated, pre-wired solution. With a unique, flexible design that provides scalability, the UPS can adapt to future changes in load demands and new requirements for higher reliability without requiring the purchase of an additional UPS. For example, the 9395 UPS enables you to add a 275 kVA UPM in the field for N+1 redundancy or capacity (dependent on static switch rating).

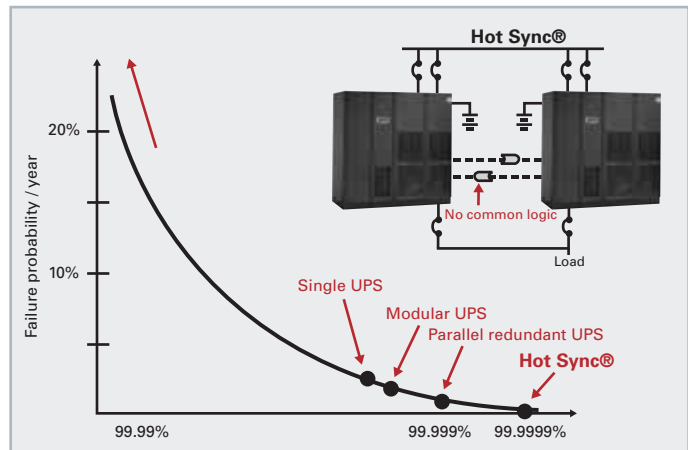

Patented Hot Sync technology provides highest availability for load

#### Key design features of Hot Sync systems

- No system-level single point of failure
- Paralleled UPMs operate completely independently. One module cannot affect or interfere with the others – no domino effect scenario
- No added circuitry is required for parallel operation. Any standard UPS can be used in a parallel system without modification
- This patented and proven technology has been successfully deployed in thousands of systems around the world



On site upgrade 550 kVA redundant

**Concurrent maintenance for higher availability**

With 9395 redundant models, Eaton field technicians can completely isolate and service a redundant module while the other module carries the load—without going to bypass for service. The 9395 also features a completely front-accessible design and can be installed against walls or back to back in multi-module configuration. This service-friendly design enhances maximum uptime and availability.

**Ease of installation**

The 9395 is a completely integrated large system that incorporates multiple power modules and system switchgear on factory pre-wired bases. Cabling busbar enters the 9395 UPS from either the top or bottom of the cabinet to provide easier and more flexible installation. Since everything is pre-wired, cabling busbar costs and installation time are significantly reduced.

**Batteries: the heart of every UPS**

When a utility power outage causes a UPS to switch to battery power, it is imperative that those batteries are healthy, charged and up to the task. Improper battery management is the number one cause of downtime. Many UPS batteries on the market today are constantly trickle-charged – a process that degrades the battery’s internal chemical composition over time, reducing potential battery service life by as much as 50%. To address this, the 9395 uses a sensing circuit and an innovative three-stage charging technique ABM technology to significantly extend battery service life and optimize recharge time. In addition, temperature-compensated charging monitors temperature changes, and adjusts the rate of charge to prolong battery life.

**Monitor batteries for optimum readiness**

Advances in firmware and digital technology enable the 9395 to offer sophisticated battery monitoring and management features that you might expect to find only on expensive add-on systems, including:

- Battery runtime remaining monitor uses system loading and trended battery discharge data plus internal sensing points for voltage and current data to calculate runtime remaining
- Battery circuit test performs a periodic full-load test of the battery string to ensure that there are no open circuits or weak cells that would jeopardize battery performance and system availability

Service this module...



**Concurrent maintenance in Power Xpert™ 9395 550 kVA**  
 ...while this module carries the load

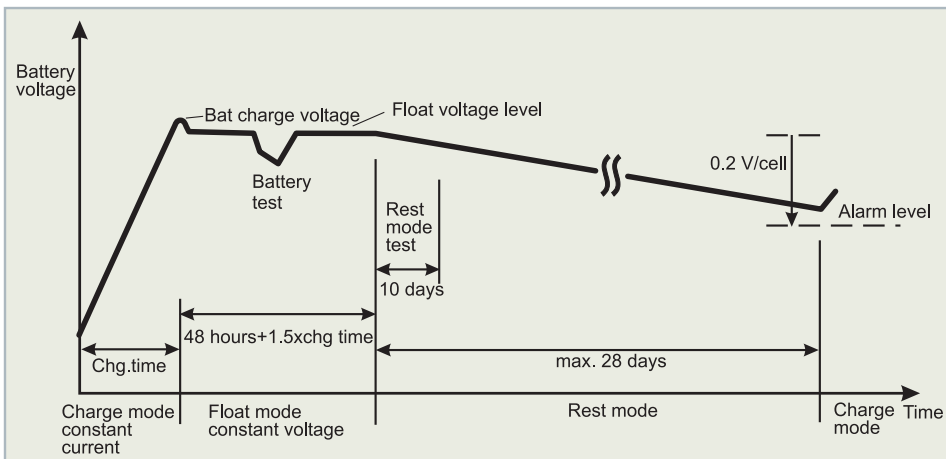

**Battery voltage during ABM charging process**

# Sustainable design lowers total cost of ownership

Due to its outstanding environmental performance, the Power Xpert™ 9395 UPS has been awarded the “An Eaton Green Solution™” label. Eaton uses this label to identify products that offer proven exceptional environmental benefits to its customers.

## Unmatched green power performance

The 9395 can operate at up to 94.5 per cent efficiency in double conversion mode and at 99 per cent in Energy Saver System mode, thus reducing utility costs and extending battery runtimes. Higher system efficiency also results in cooler operating conditions, which in turn reduces air conditioning costs, extends the life of UPS components, and increases overall reliability, availability and performance. The environmental impact of using the 9395 is minimised due to its sustainable design and the resulting cost savings.

## Greatly reduced footprint

Compared to traditional UPS designs, a transformer-free UPS typically weighs 50 per cent less and occupies only 60 per cent of the floorspace. In addition, the transformer-free technology is highly efficient even at half load capacity.

The 9395 fits a redundant design into the same footprint as a traditional, non-redundant UPS. Unlike some larger and heavier systems, the 9395 fits easily through all doors, can be transported on freight elevators, and there is no need to dismantle it to fit it on elevators or through doorways, which can cause significant delays and increase costs. Therefore, the 9395's smaller footprint not only reduces your total cost of ownership, but also minimises the impact on shipping.

## Easy Capacity Test reduces testing time and costs

With the Easy Capacity Test, the 9395 can test its entire power train under full load stress, including the rectifier, inverter, contactors, fuses, power busses, cabling, bypass (static switch), magnetics and filter capacitors – all without an external load being connected.

The net result of this innovative load test is that there are no load banks to rent, no temporary load connections to make and no wasted energy, saving you time and money during startup and commissioning tests.

Eaton field technicians are trained to use this load testing capability during service startup to ensure optimum calibration, maximum efficiency and inherent redundancy.

## Power Xpert™ 9395 – An Eaton Green Solution

- Less source materials
- Less energy required during manufacturing and testing
- Smaller footprint
- Less energy needed during use, less electrical and cooling costs
- Reduced end-of-life impact



## An Eaton Green Solution

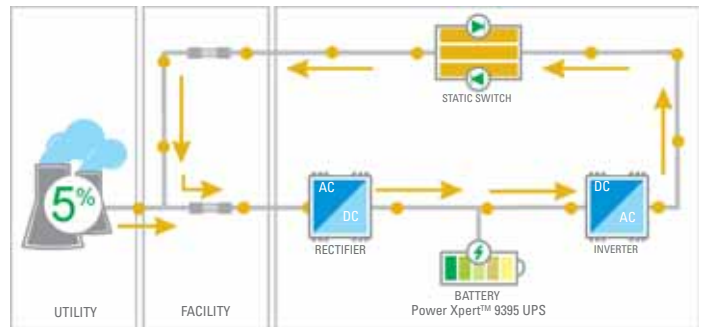

Easy Capacity Test power flow

# Energy Advantage Architecture (EAA)

The Eaton Advantage Architecture (EAA) is an umbrella name for the complementary, innovative energy-saving technologies by Eaton – Energy Saver System (ESS) and Variable Module Management Systems (VMMS) – which offer new ways to maximise UPS energy efficiency without compromising on reliability. These technologies allow engineers and facility managers to get the best possible performance from their UPS while reducing financial and environmental costs.

## Variable Module Management System (VMMS)

Most UPS installations are only loaded between 20-40 per cent, but UPSs are not optimally efficient when used at these lighter loads. As a key component of EAA, the VMMS technology maximises parallel UPS system efficiencies at low load levels while supplying continuous double-conversion power.

VMMS optimally employs uninterruptible power modules (UPMs) in the UPS to achieve higher efficiencies in double-conversion mode. By switching UPMs that are not needed to ready state, the percentage load level of the active UPMs is maximised.

This is calculated according to the VMMS load threshold of the UPMs (80 per cent by default) and the redundancy requirements specified in the system configuration. The result is maximised energy savings.

In the event of an increased load level on a critical bus, all ready-state UPMs are able to revert quickly to double-conversion mode by connecting the existing PWM signals to the IGBT gates.

VMMS is made possible through the Power Xpert™ 9395 modular design. It can also be applied in multi-module single-UPS systems.

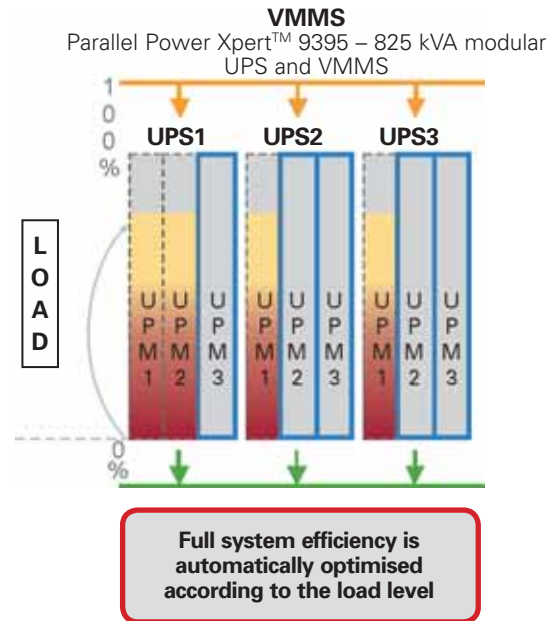

Input power quality within load tolerance

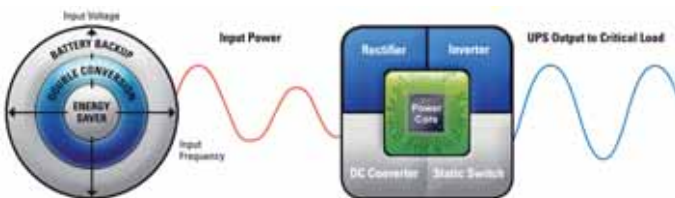

Input power quality within rectifier tolerance



Input power quality out of rectifier tolerance

## Energy Saver System (ESS)

Energy Saver System technology enables UPS efficiency to reach an impressive 99 per cent. ESS allows the UPS to switch between three configurable operating modes:

- 1) In standard double-conversion mode the UPS operates normally, supplying power through the power converters.
- 2) In Energy Saver System mode the power converters are in ready state and the static bypass switch allows the UPS to supply power from the mains directly. If mains power is lost or exceeds preset output limits, the DC link that is kept active seamlessly switches to double conversion in less than two milliseconds. While in ESS mode, the UPS is also able to detect whether an output fault has been caused by a source or by a load. A fault at the bypass source results in immediate switchover to the inverter, whereas a fault in the load keeps the UPS in Energy Saver System mode.
- 3) In high-alert mode the UPS switches from Energy Saver System to double conversion for one hour. Power quality is constantly controlled during this time. If a high-alert command is received again, for example due to a thunderstorm, the one-hour timer will be reset.

## Components engaged in different ESS operating modes

# Meeting the needs of data centres

## Meeting the power quality needs of mega data centres

For customers with massive power supply needs, Eaton offers a choice between two technical solutions for paralleling 9395 systems to best match their power quality requirements:

- 1) Distributed bypass – where every UPS unit in the system has an individually controlled Integrated System Bypass Module (ISBM).
- 2) Centralised bypass – where all UPS units use a common system-rated, high-power, static-bypass switch.

Both solutions allow the use of Eaton's technologies Energy Saver System (ESS) and Variable Module Management System (VMMS) for enhanced efficiency and substantial energy savings.

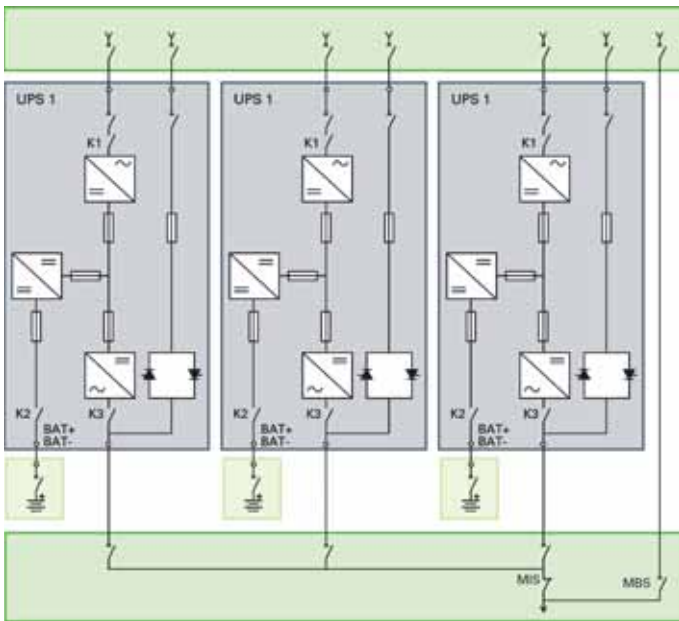

Parallel system with a distributed bypass

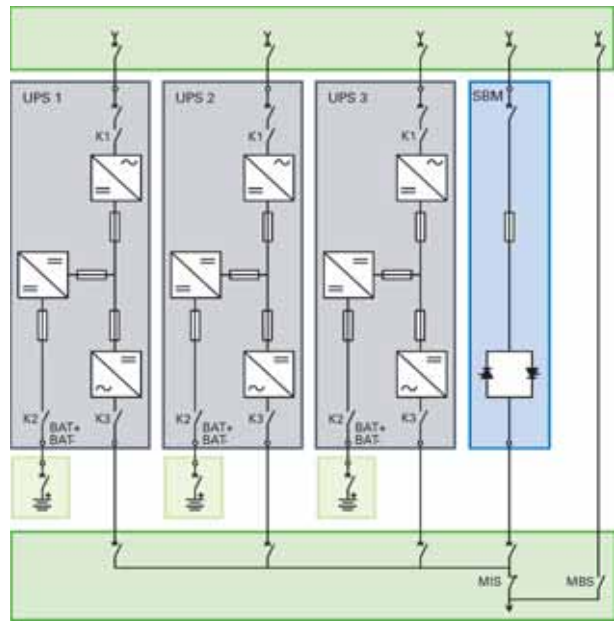

Parallel system with a centralised bypass

## Building a centralised bypass solution with Power Xpert™ 9395 SBM

An Power Xpert™ 9395 SBM is built to deliver custom, multi-module UPS configurations with a centralised bypass. The SBM can be used with UPS systems from 2,000 amperes up to 5,000 amperes (1.4 – 3.5 MVA) and is capable of paralleling UPS units with unequal kVA ratings – for example, one 550 kVA unit and one 275 kVA unit, or three 825 kVA units with one 550 kVA unit.

## Sync Control

Sync Control ensures that the output of two or more separate UPSs (single modules or parallel systems) remain in phase with each other, so that the static transfer switches connecting separate distribution paths may seamlessly change state when necessary.



The Power Xpert™ 9395 SBM cabinet



# Extensive configurability

## Web card

Power Xpert™ 9395 UPS comes equipped with a ConnectUPS Web/ SNMP card. This tool is a complete UPS monitoring, control and shutdown solution for a networked IT environment. In case of alert, the Web/SNMP card notifies users and administrators through e-mail. During a prolonged power failure the protected computer systems can also be shut down smoothly with Intelligent Power Protector software.



The ConnectUPS-X Web/SNMP Card allows you to connect your 9395 directly to the ethernet and the internet. This unique solution allows you to conveniently monitor and manage your UPS with a standard Web browser. As an added feature, the unique three-port switching hub on the X-Slot model provides additional network connections.

## Intelligent Power software

Eaton's Intelligent Power Manager (IPM) is a user-friendly monitoring tool for UPSs, ePDUs and environmental sensors. It collects data through the network, storing it in a database to view and analysis later. IPM has a powerful alarm function which collects alarm events from individual devices and sends alerts through e-mail.

Intelligent Power Protector (IPP) performs an orderly and controlled shutdown of powered computers in case a power failure exceeds the battery backup time. IPM can be used to monitor and manage all IPPs running in the network, which dramatically reduces the workload of administrators and minimises the possibility of error.

Intelligent Power software is a welcome addition to today's virtualised data centre. Web-based interfaces simplify usage, allowing access from any computer in the LAN or remotely via the internet. IPM integrates seamlessly with the leading virtualisation management tool, VMware vCenter. It can even trigger vMotion to move virtual machines to other servers or sites if there is a fear of power loss, resulting in zero downtime. IPP supports traditional server operating systems as well as VMware ESX and Microsoft Hyper-V virtual environments.



# Customised solutions

The 9395 is Eaton's answer to customers that need tailor-made solutions for mega data centres requiring high power performance, maximum availability and costs savings. Eaton's project management team, Large Systems Group (LSG), works together with our local sales and project management teams to fulfil customer needs and to meet the sophisticated requirements set by demanding installations, environment and load applications.

For example, UPSs used in marine environments have special dependability requirements due to the harsh environmental conditions they have to withstand and the critical nature of the equipment they protect. Eaton has supplied marine UPSs to hundreds of vessels over the years.

Eaton offers customised 9395-based systems for different markets, including:

- Mega data centres
- Marine and off-shore
- Oil and gas
- Rail and track, underground, traffic, tunnel, mines
- Aviation
- Industrial applications
- Defence/military



# Unmatched green efficiency

## An Eaton Green Solution

The Power Xpert™ 9395 UPS dramatically improves energy efficiency and sustainability, while offering a much smaller footprint than legacy system.

- **Less energy during use**

Operating at 94.3% efficiency in double conversion mode and 99% in ESS, the 9395 requires less power, which in turn creates cooler operating conditions, reducing air conditioning requirements and extending the life of UPS components and batteries.

- **Less energy during manufacturing**

The new design requires 50-80% less energy in manufacturing due to less energy required for testing and to the smaller configuration.

- **Smaller footprint**

50%-70% weight reduction is realized due to the much smaller footprint, thus minimizing impact of shipping and reducing freight costs.

- **Less source materials**

Source materials such as steel and copper are much less than in legacy systems. This reduction is possible due to the transformer-free technology.

- **Reduced end-of-life impact**

The Eaton UPS business model supports recycling. 90% of the materials can be recycled, further decreasing end-of-life impact.

Due to these outstanding green performance, the Power Xpert™ 9395 has earned the "An Eaton Green Solution™" label used by Eaton to identify products that offer proven exceptional environmental benefits to the customers.



## An Eaton Green Solution



Power Xpert™ 9395 exemplifies Eaton's way of doing business right, helping our customers utilize electrical power more efficiently while paying attention to sustainable values.

At Eaton, we apply ISO 14001 Environmental Management System, on site and R&D certification to all of our facilities. The implementation of ISO 14001 has resulted in dramatic reductions of energy and water consumption at the plant. Also the amount of mixed waste has been cut by 80% since 2002.

Eaton is proud to endorse the RoHS (Restriction on Hazardous Substances) and the WEEE directive (Waste Electrical and Electronic Equipment Directive) through the development of non-hazardous products and sound disposal of harmful electrical materials in support of a safer environment.

A significant part of 9395 components complies with RoHS initiative, such as:

- Mechanics
- Cable harnesses
- Electromechanical components
- Printed circuit components (except solder alloy)

Strategies have been deployed to guarantee proper collection and disposal of materials falling within WEEE restriction.

Product specific end-of-life instructions included in the manuals provide information for environmentally friendly disposal of batteries, electrical and electronic components.

# Eaton Power Xpert™ 9395 UPS 200 - 1100 kVA

## TECHNICAL SPECIFICATIONS

### UPS output power rating

|     |     |     |     |     |     |     |     |     |     |      |
|-----|-----|-----|-----|-----|-----|-----|-----|-----|-----|------|
| kVA | 200 | 225 | 275 | 300 | 400 | 450 | 550 | 600 | 825 | 1100 |
| kW  | 180 | 202 | 247 | 240 | 360 | 405 | 495 | 480 | 742 | 990  |

### General

|                                                   |                                                 |
|---------------------------------------------------|-------------------------------------------------|
| Efficiency in double conversion mode (full load)  | >94%                                            |
| Efficiency in double conversion mode (half load)  | >93%                                            |
| VMMS (double conversion)                          | significantly increased efficiency at low loads |
| Efficiency in Energy Saver System (ESS)           | up to 99%                                       |
| Distributed parallelling with Hot Sync technology | 5 + 1                                           |
| Internal N+1 redundance capable                   | Yes                                             |
| Inverter/rectifier topology                       | transformer-free IGBT with PWM                  |
| Audible noise                                     | 75 - 81.5 dBA @ 1m, model dependant             |
| Altitude (max)                                    | 1000 m without derating (max 2000 m)            |

### Input

|                                       |                                                       |
|---------------------------------------|-------------------------------------------------------|
| Input wiring                          | 3 ph + N + PE                                         |
| Nominal voltage rating (configurable) | 220/380, 230/400, 240/415 V 50/60 Hz                  |
| Input voltage range                   | +10% / -15%, +10% / -10% for bypass                   |
| Input frequency range                 | 45-65 Hz                                              |
| Input power factor                    | 0.99                                                  |
| Input ITHD                            | < 3-5% on nominal load, depending on the utility UTHD |
| Soft start capability                 | Yes                                                   |
| Internal backfeed protection          | Yes, standard (except on 200/400kVA models)           |

### Output

|                                       |                                                                                       |
|---------------------------------------|---------------------------------------------------------------------------------------|
| Output wiring                         | 3 ph + N + PE                                                                         |
| Nominal voltage rating (configurable) | 220/380, 230/400, 240/415 V 50/60 Hz                                                  |
| Output UTHD                           | <3% (100% linear load);<br><5% (reference non linear load)                            |
| Output power factor                   | 0.9 (0.8 for 300 & 600 kVA)                                                           |
| Permitted load power factor           | 0.7 lagging - 0.8 leading                                                             |
| Overload on inverter                  | 10 min 100-110%; 30 sec 110-125%;<br>10 sec 125-150%; 300 ms >150%                    |
| Overload when bypass available        | Continuous <115%, 20 ms 1000%<br>Note: Bypass fuses may limit the overload capability |

### Battery

|                                             |                              |     |     |     |     |               |     |     |     |      |
|---------------------------------------------|------------------------------|-----|-----|-----|-----|---------------|-----|-----|-----|------|
| Type                                        | VRLA, AGM, Gel, Wet Cell     |     |     |     |     |               |     |     |     |      |
| Charging method                             | ABM technology or Float      |     |     |     |     |               |     |     |     |      |
| Temperature compensation                    | with EMP                     |     |     |     |     |               |     |     |     |      |
| Battery nominal voltage (lead-acid)         | 480 V (40 x 12 V, 240 cells) |     |     |     |     |               |     |     |     |      |
| Charging current / ModelDefault A           | 200                          | 225 | 275 | 300 | 400 | 450           | 550 | 600 | 825 | 1100 |
|                                             | 40                           | 40  | 40  | 38  | 80  | 80            | 80  | 76  | 120 | 160  |
| <b>Dimensions and weights</b>               | <b>W x D x H</b>             |     |     |     |     | <b>Weight</b> |     |     |     |      |
| 200kVA                                      | 1350 x 880 x 1800            |     |     |     |     | 810 kg        |     |     |     |      |
| 225, 275 and 300kVA                         | 1350 x 880 x 1880            |     |     |     |     | 830 kg        |     |     |     |      |
| 450/550/600kVA and 225/275/300kVA redundant | 1890 x 880 x 1880            |     |     |     |     | 1430 kg       |     |     |     |      |
| 450/550 kVA redundant                       | 2520 x 880 x 1880            |     |     |     |     | 2030 kg       |     |     |     |      |
| 275 kVA field upgrade UPS-U                 | 740 x 880 x 1880             |     |     |     |     | 600 kg        |     |     |     |      |
| 825 kVA                                     | 3710 x 880 x 1880            |     |     |     |     | 2730 kg       |     |     |     |      |
| 1100 kVA and 825 kVA redundant              | 4450 x 880 x 1880            |     |     |     |     | 3330 kg       |     |     |     |      |

### Accessories

External battery cabinets with long-life batteries, X-Slot connectivity (Web/SNMP, ModBus/Jbus, Relay, Hot Sync, ViewUPS-X remote display)

### Communications

|                      |                      |
|----------------------|----------------------|
| X-Slot               | 4 communication bays |
| Serial ports         | 1 available          |
| Relay inputs/outputs | 5/1 programmable     |

### Compliance with standards

|             |                          |
|-------------|--------------------------|
| Safety      | IEC 62040-1, IEC 60950-1 |
| EMC         | IEC 62040-2              |
| Performance | IEC 62040-3              |

In the interests of continuous product improvement all specifications are subject to change without notice.

**SINGAPORE**

Tel : +65 6825 1684

Fax : +65 6825 1689

EatonSEA@eaton.com

[www.eaton.com/powerquality](http://www.eaton.com/powerquality)

**INDONESIA**

Tel : +62 21 2949 9000

Fax : +62 21 2949 9001

**MALAYSIA**

Tel : +603 7804 3618

Fax : +603 7803 6193

**THAILAND**

Tel : +66 2575 0530

Fax : +66 2575 1579

**VIETNAM**

Hanoi

Tel : +84 4 3936 5303

Fax : +84 4 3936 5307

Ho Chi Minh

Tel : +84 8 6255 6737

Fax : +84 8 6255 6801

Eaton is the trade name, trademark, and/  
or service mark of Eaton Corporation or its  
subsidiaries and affiliates.



*Powering Business Worldwide*

© 2008 Eaton Corporation  
All Rights Reserved  
Printed in Singapore  
July 2012